

REG	STATE	PROJECT	SHEET NO.	TOTAL SHEETS
	D.C.			

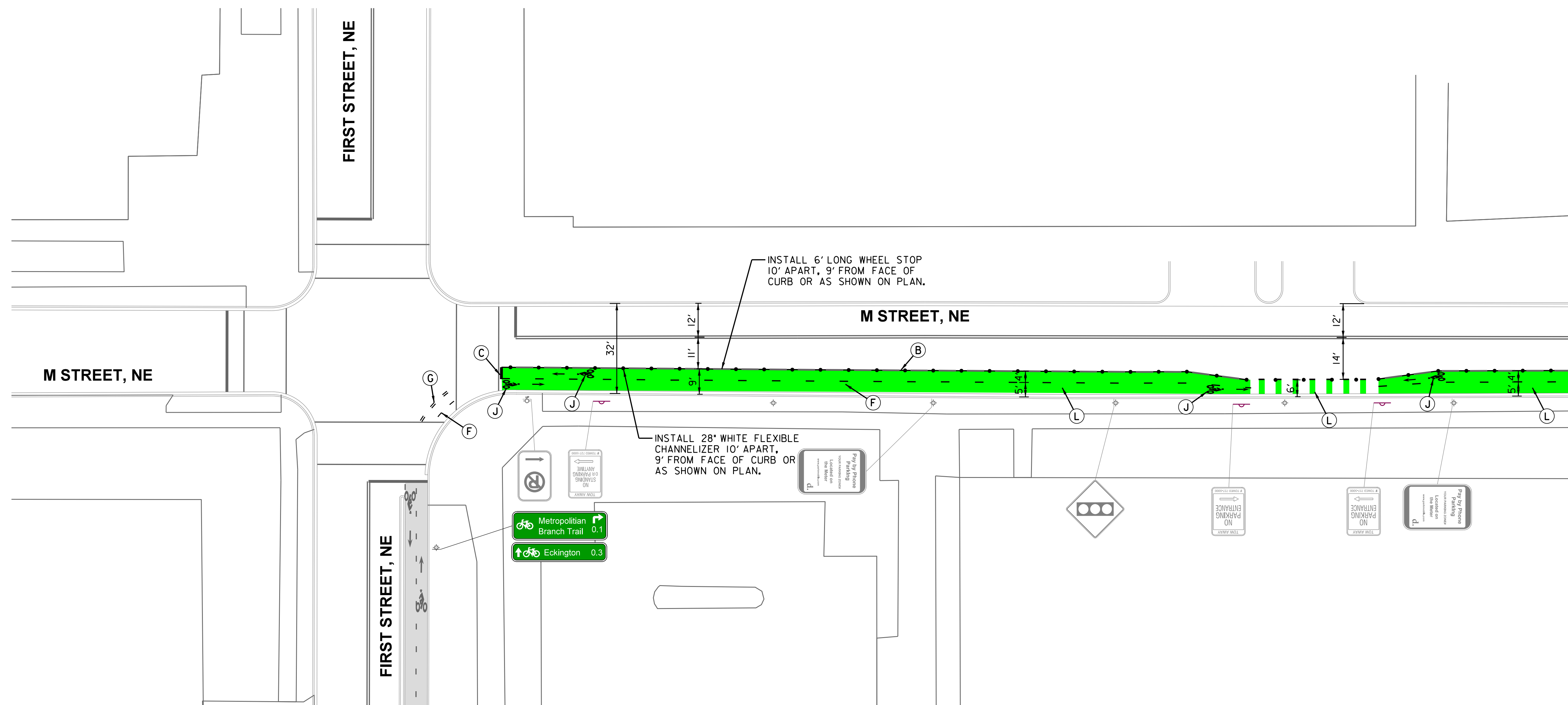

MATCH LINE SEE STRIPING PLAN - 2

PAVEMENT MARKING LEGEND

- (A) 4" SOLID WHITE REFLECTIVE THERMOPLASTIC PAVEMENT MARKING LINE
- (B) 6" SOLID WHITE REFLECTIVE THERMOPLASTIC PAVEMENT MARKING LINE
- (C) 12" SOLID WHITE REFLECTIVE THERMOPLASTIC PAVEMENT MARKING LINE
- (D) 4" WHITE REFLECTIVE THERMOPLASTIC PAVEMENT MARKING (2' STRIPE/4' GAP/2' STRIPE)
- (E) 6" WHITE REFLECTIVE THERMOPLASTIC PAVEMENT MARKING (2' STRIPE/4' GAP/2' STRIPE)
- (F) 4" YELLOW REFLECTIVE THERMOPLASTIC PAVEMENT MARKING (2' STRIPE/4' GAP/2' STRIPE)
- (G) 4" DOUBLE WHITE REFLECTIVE THERMOPLASTIC PAVEMENT MARKING (3' STRIPE/9' GAP/3' STRIPE)
- (H) 6"/4" WHITE/YELLOW REFLECTIVE THERMOPLASTIC PAVEMENT MARKING (2' STRIPE/4' GAP/2' STRIPE) WITH RIDE-A-WAY™ LIGHT GREEN COATING (3 COATS) BETWEEN MARKINGS
- (J) → PERMANENT PREFORMED PAVEMENT MARKING BIKE LANE SYMBOL
- (K) ← PERMANENT PREFORMED PAVEMENT MARKING SHARED LANE SYMBOL
- (L) RIDE-A-WAY™ LIGHT GREEN COATING (3 COATS)

60% SUBMITTAL: SEPTEMBER, 2014

D.C. DEPARTMENT OF TRANSPORTATION
POLICY, PLANNING, AND SUSTAINABILITY ADMINISTRATION
BICYCLE AND PEDESTRIAN PROGRAM

M STREET, NE CYCLE TRACK
FROM FIRST STREET, NE TO
DELEWARE AVE, NE

STRIPING PLAN - 1

PROJECT ENG. _____ MUG
DESIGNED BY _____ KSK
CHECKED BY _____ MUG
DRAWN BY _____ KSK
PROJECT MGR. _____ MUG

DIVISION CHIEF

DATE: 06/04/14

FILE: _____

SHEET _____ OF _____



NO.	DESCRIPTION	NAME	DATE

REVISIONS

REG	STATE	PROJECT	SHEET NO.	TOTAL SHEETS
	D.C.			

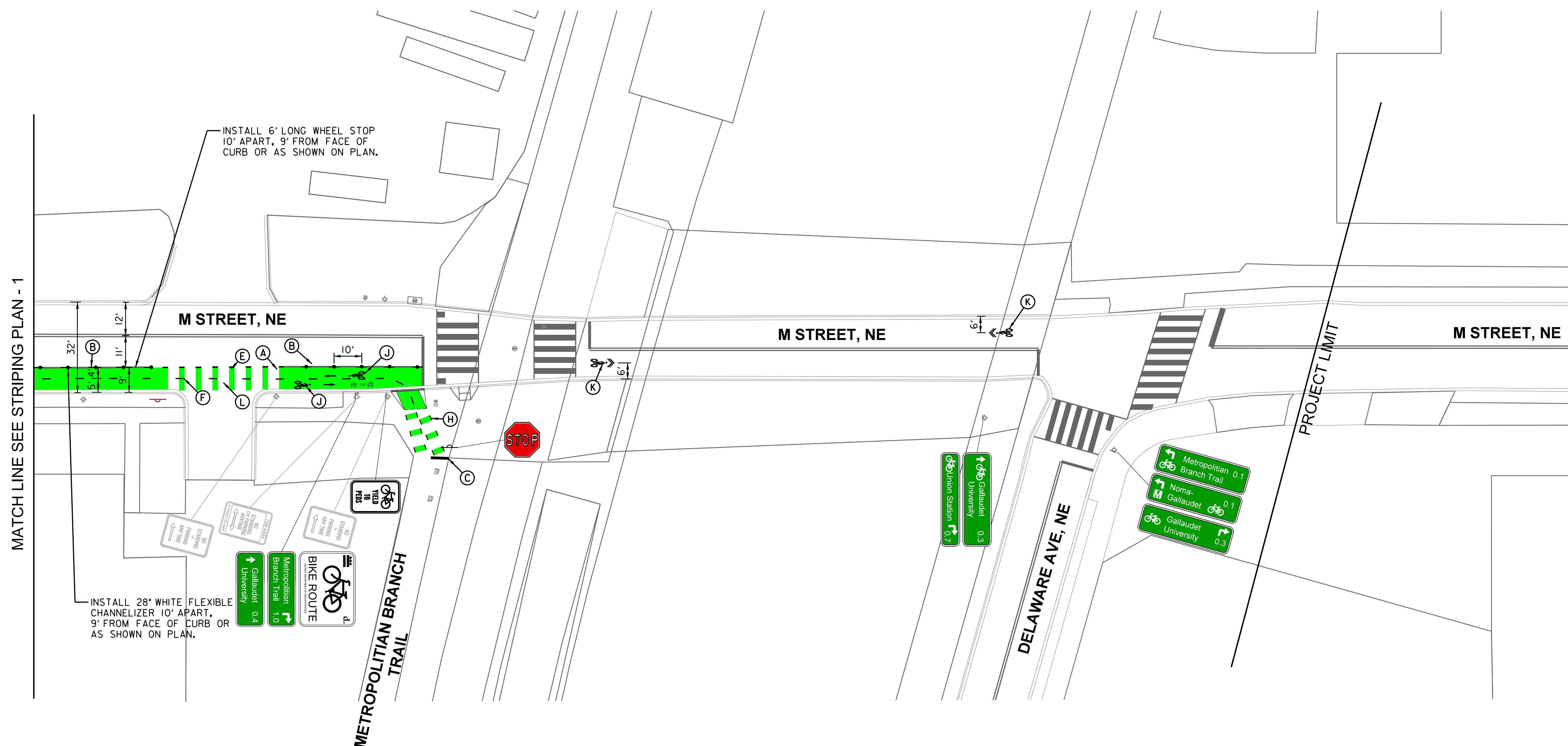

MATCH LINE SEE STRIPING PLAN - 1

INSTALL 6' LONG WHEEL STOP
10' APART, 9' FROM FACE OF
CURB OR AS SHOWN ON PLAN.

INSTALL 28" WHITE FLEXIBLE
CHANNELIZER 10' APART,
9' FROM FACE OF CURB OR
AS SHOWN ON PLAN.

- PAVEMENT MARKING LEGEND**
- (A) 4" SOLID WHITE REFLECTIVE THERMOPLASTIC PAVEMENT MARKING LINE
 - (B) 6" SOLID WHITE REFLECTIVE THERMOPLASTIC PAVEMENT MARKING LINE
 - (C) 12" SOLID WHITE REFLECTIVE THERMOPLASTIC PAVEMENT MARKING LINE
 - (D) 4" WHITE REFLECTIVE THERMOPLASTIC PAVEMENT MARKING (2' STRIPE/4' GAP/2' STRIPE)
 - (E) 6" WHITE REFLECTIVE THERMOPLASTIC PAVEMENT MARKING (2' STRIPE/4' GAP/2' STRIPE)
 - (F) 4" YELLOW REFLECTIVE THERMOPLASTIC PAVEMENT MARKING (2' STRIPE/4' GAP/2' STRIPE)
 - (G) 4" DOUBLE WHITE REFLECTIVE THERMOPLASTIC PAVEMENT MARKING (3' STRIPE/9' GAP/3' STRIPE)
 - (H) 6"/4" WHITE/YELLOW REFLECTIVE THERMOPLASTIC PAVEMENT MARKING (2' STRIPE/4' GAP/2' STRIPE) WITH RIDE-A-WAY™ LIGHT GREEN COATING (3 COATS) BETWEEN MARKINGS
 - (J) PERMANENT PREFORMED PAVEMENT MARKING BIKE LANE SYMBOL
 - (K) PERMANENT PREFORMED PAVEMENT MARKING SHARED LANE SYMBOL
 - (L) RIDE-A-WAY™ LIGHT GREEN COATING (3 COATS)



NO.	DESCRIPTION	NAME	DATE

60% SUBMITTAL: SEPTEMBER, 2014

D.C. DEPARTMENT OF TRANSPORTATION
POLICY, PLANNING, AND SUSTAINABILITY ADMINISTRATION
BICYCLE AND PEDESTRIAN PROGRAM

M STREET, NE CYCLE TRACK
FROM FIRST STREET, NE TO
DELEWARE AVE, NE

STRIPING PLAN - 2

PROJECT ENG. _____ MUG	DIVISION CHIEF
DESIGNED BY _____ KSK	DATE _____ 06 /04 /14
CHECKED BY _____ MUG	FILE _____
DRAWN BY _____ KSK	SHEET _____ OF _____
PROJECT MGR. _____ MUG	

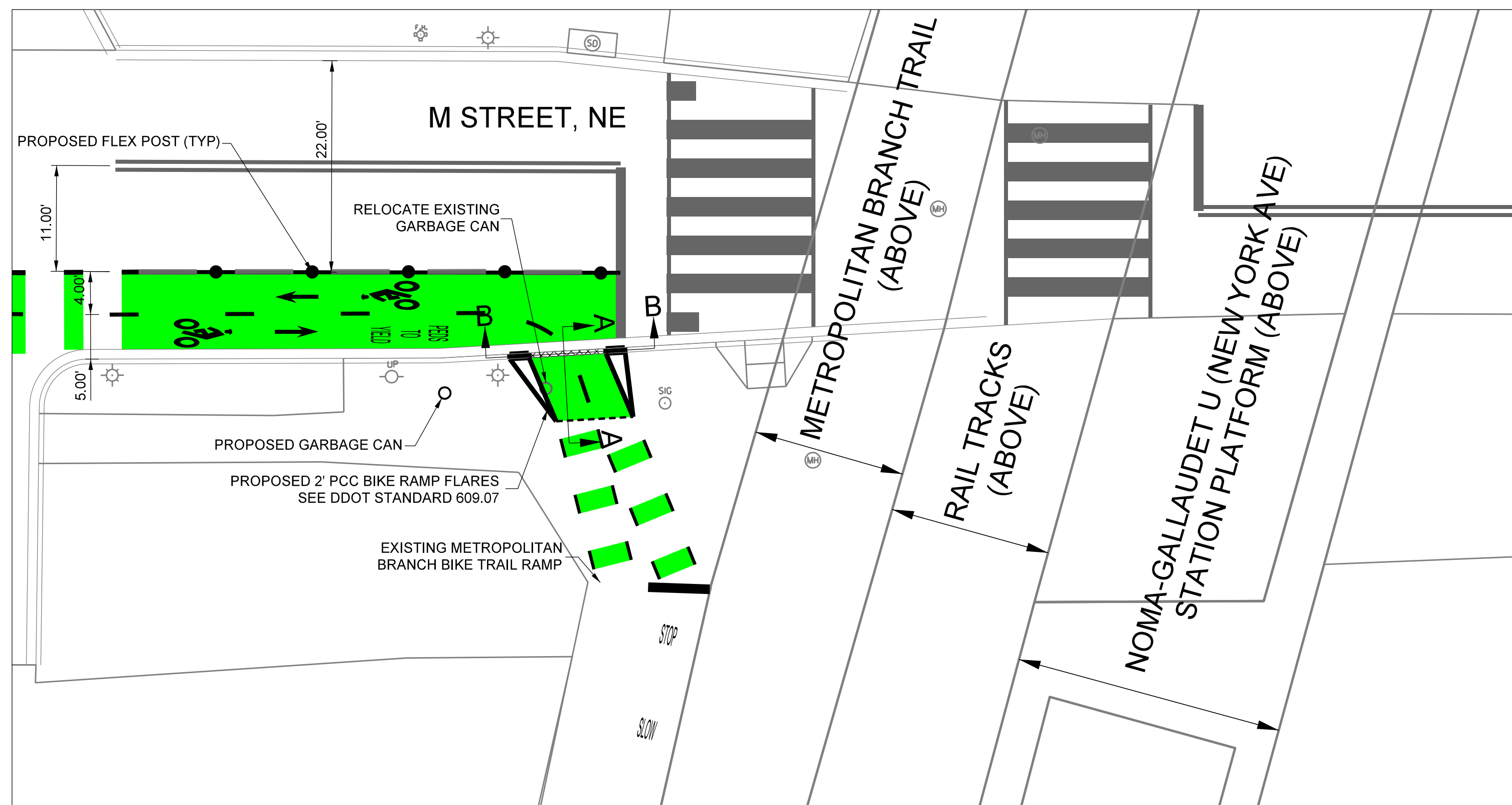

1 CYCLE TRACK RAMP PLAN VIEW
SCALE: 1"=20'

GENERAL NOTES:

1. CURB ELEVATIONS ARE APPROXIMATE / RELATIVE AND REQUIRE FIELD VERIFICATION FROM CONTRACTOR.

LEGEND:

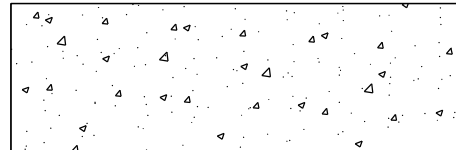
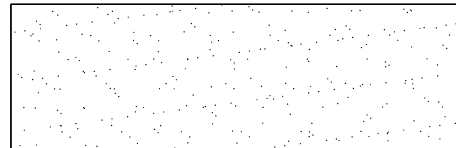
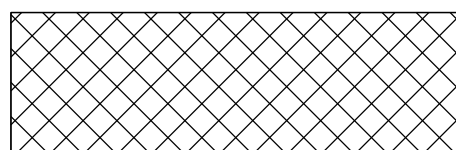
-  PROPOSED PCC
-  PROPOSED CR-6
-  GRANITE CURB TO DEMOLISH

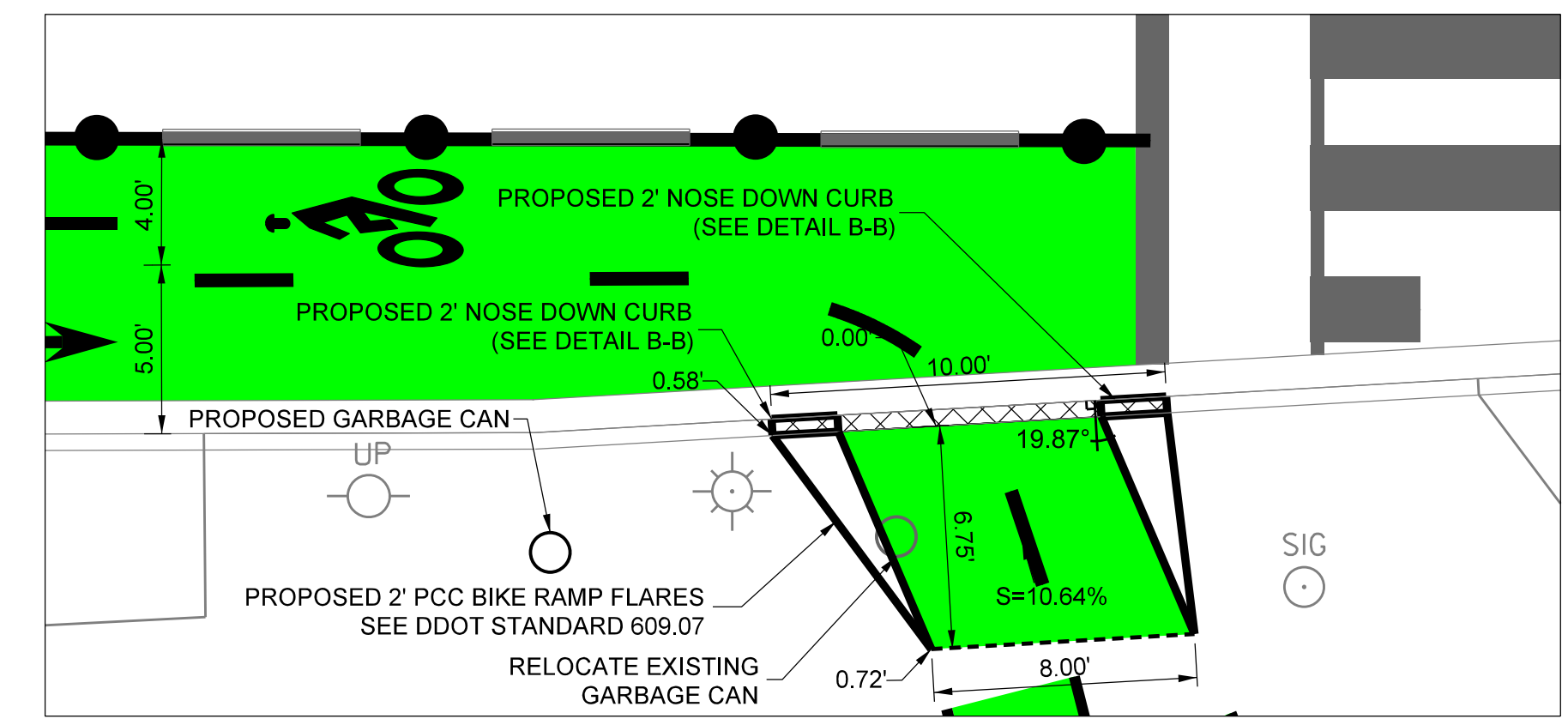

2 CYCLE TRACK RAMP ELEVATION DETAILS
SCALE: 1"=10'

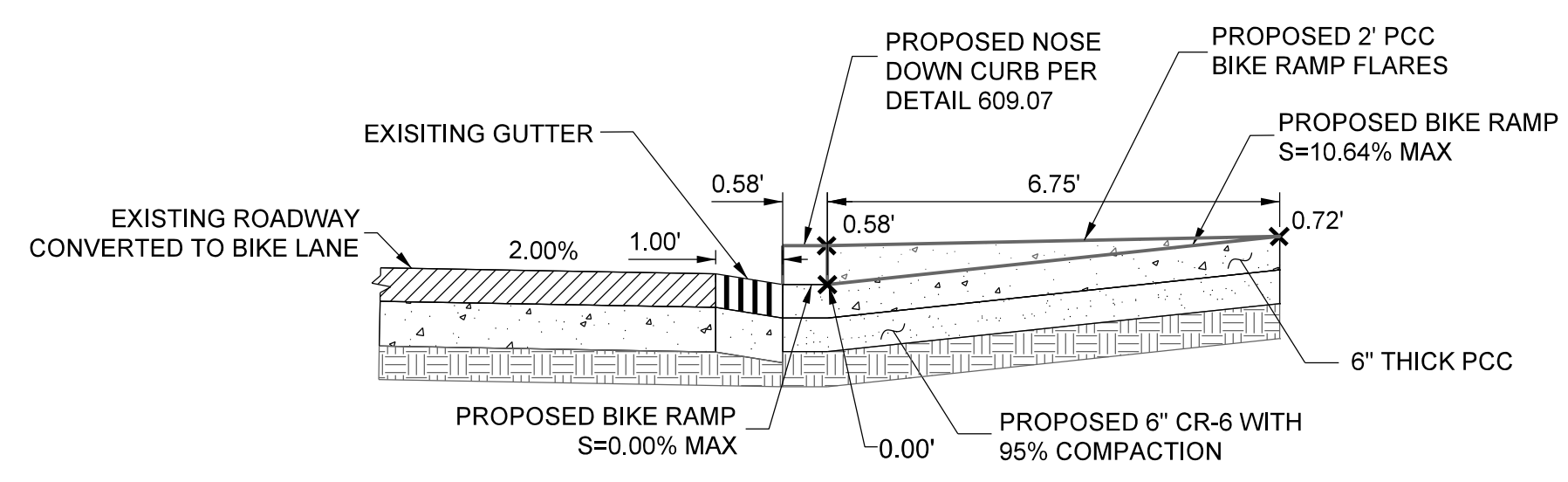

A-A CYCLE TRACK RAMP SECTION
SCALE: 1" = 5'

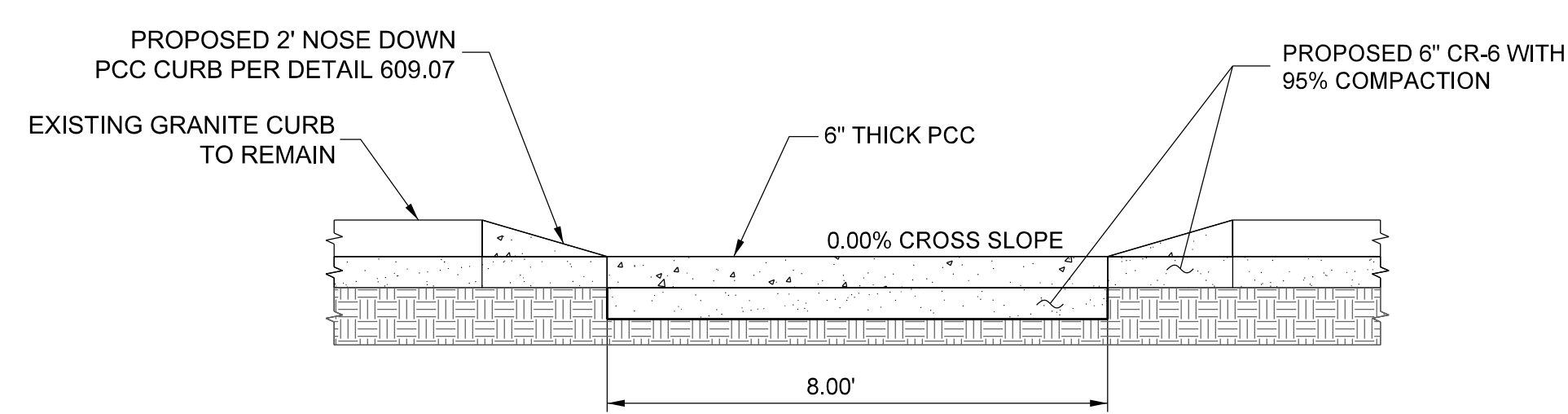

B-B CYCLE TRACK RAMP CROSS SECTION
SCALE: 1" = 5'

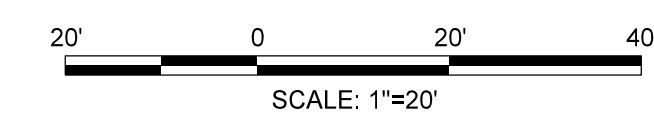

60% SUBMITTAL: SEPTEMBER, 2014

D.C. DEPARTMENT OF TRANSPORTATION
POLICY, PLANNING, AND SUSTAINABILITY ADMINISTRATION
BICYCLE AND PEDESTRIAN PROGRAM

M STREET, NE CYCLE TRACK
FROM FIRST STREET, NE TO
DELEWARE AVE, NE

STRIPING PLAN -

PROJECT ENG.	MJG
DESIGNED BY	KSK
CHECKED BY	MJG
DRAWN BY	KSK
PROJECT MGR.	MJG
DIVISION CHIEF	
DATE	06/04/14
FILE	
SHEET	OF



NO.	DESCRIPTION	NAME	DATE
REVISIONS			

REG	STATE	PROJECT	SHEET NO.	TOTAL SHEETS
	D.C.			

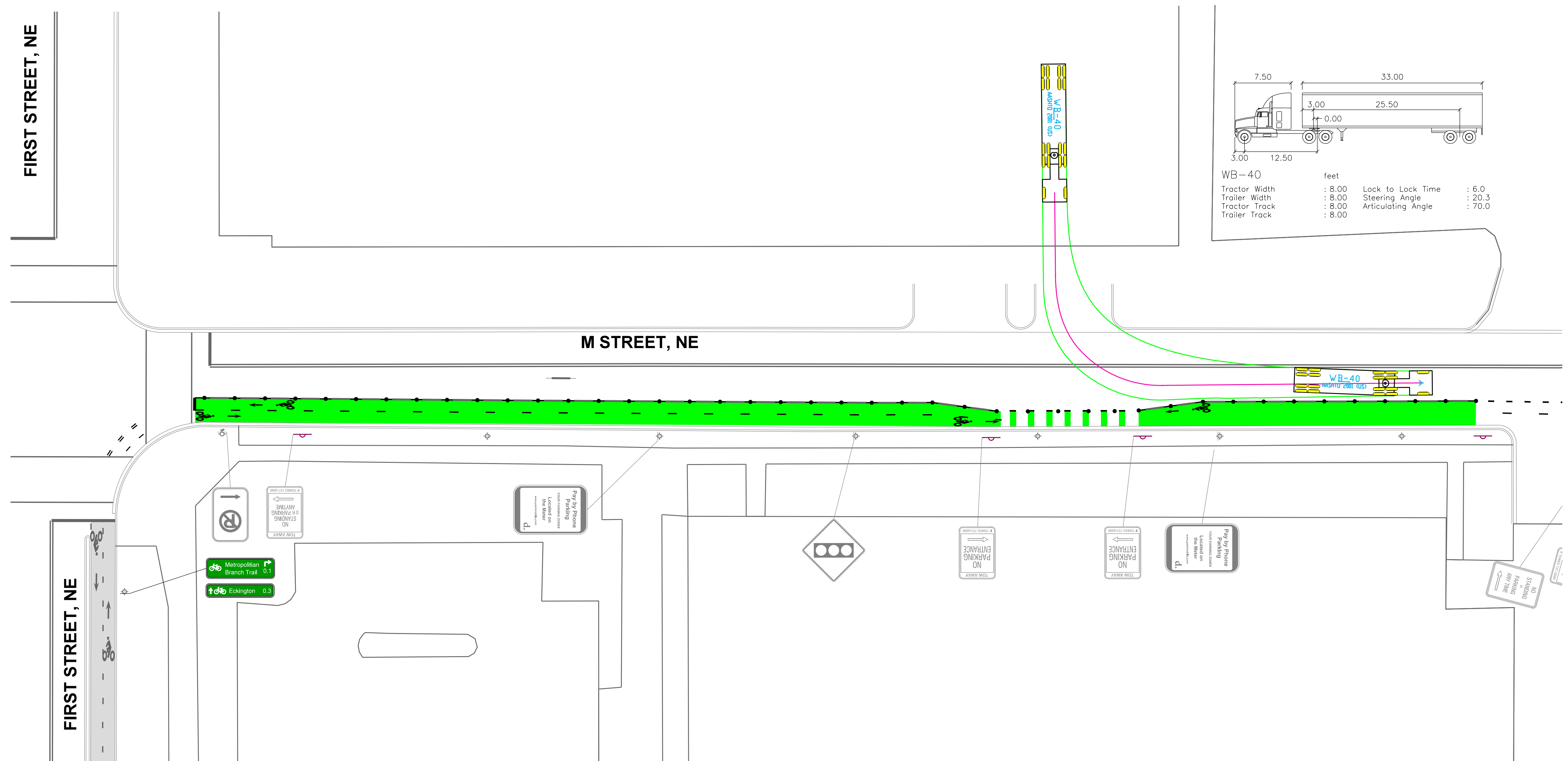
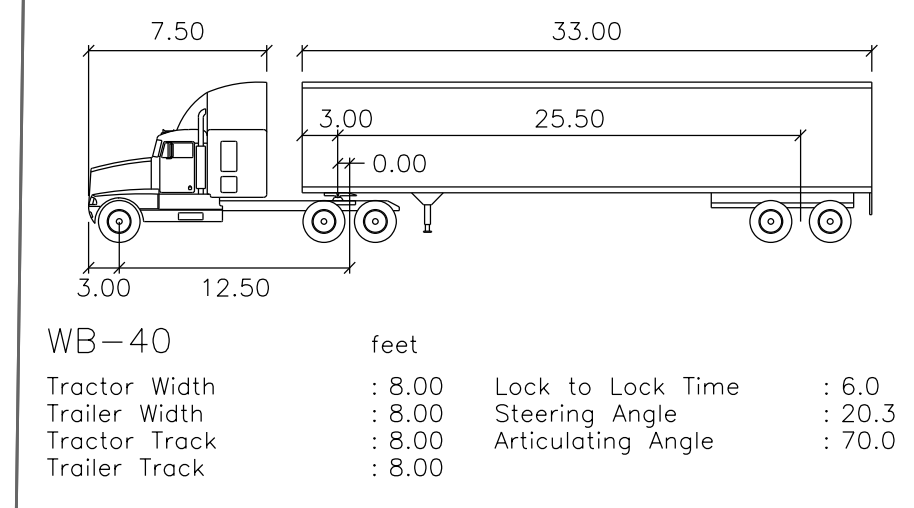
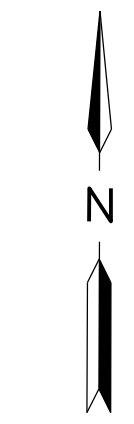

60% SUBMITTAL: SEPTEMBER, 2014

D.C. DEPARTMENT OF TRANSPORTATION
POLICY, PLANNING, AND SUSTAINABILITY ADMINISTRATION
BICYCLE AND PEDESTRIAN PROGRAM

M STREET, NE CYCLE TRACK
FROM FIRST STREET, NE TO
DELEWARE AVE, NE

AUTOTURN TEST

PROJECT ENG. MJG
DESIGNED BY KSK
CHECKED BY MJG
DRAWN BY KSK
PROJECT MGR. MJG

DIVISION CHIEF

DATE 06 / 04 / 14
FILE
SHEET OF



NO.	DESCRIPTION	NAME	DATE